

VALIANT 32
Designed by
Robert Perry

WESTERBEKE L-25 LIGHTWEIGHT MARINE DIESEL ENGINE

Features:

- **Lightweight**
about the same as a
gasoline engine of
similar performance.
- **Rugged and
Dependable**
strong where strength
is needed.
- **Ideal for Ocean Racers**
where weight is important.
- **Smooth and Quiet**
for cruising.

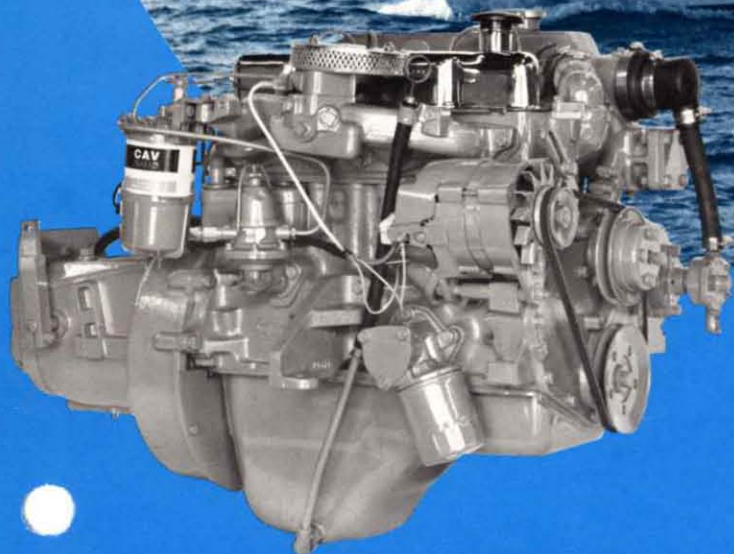

WESTERBEKE L 25
with J type manual gear

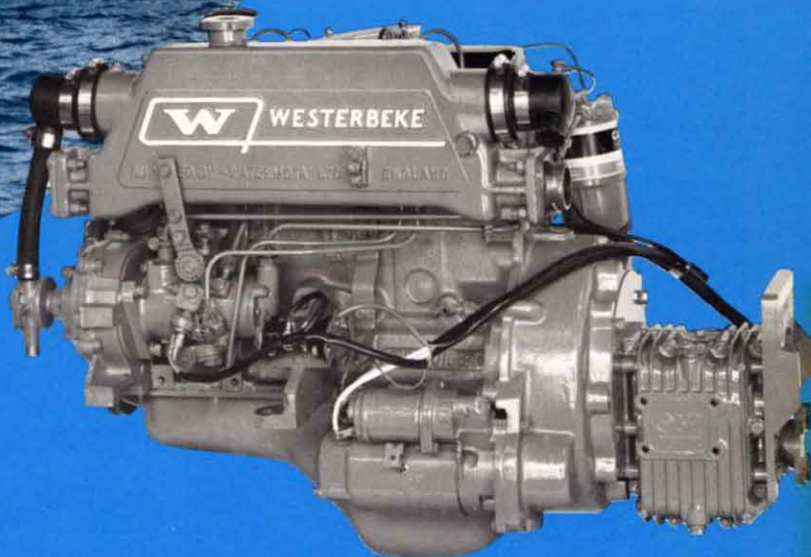

WESTERBEKE L 25
with short profile sailing gear

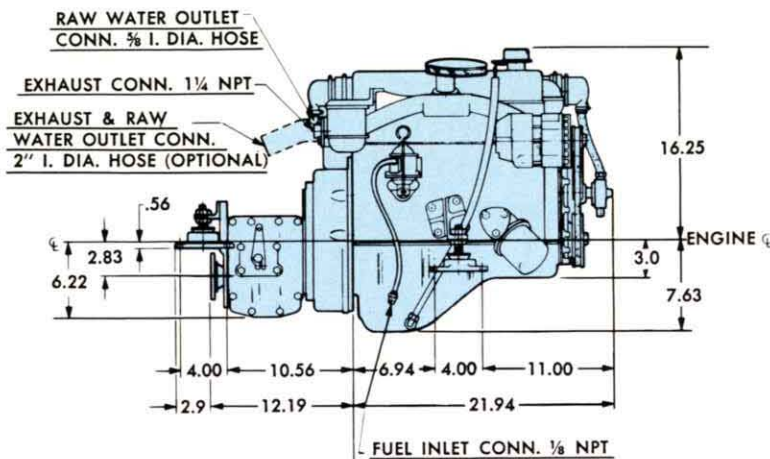

Installation drawing of Westerbeke L-25 with 2:1 short profile freewheeling sailing gear. Weight 25 pounds. Turns right hand propeller. Short profile gear also available with vee drive, 2:1 or 2.6:1 reduction.

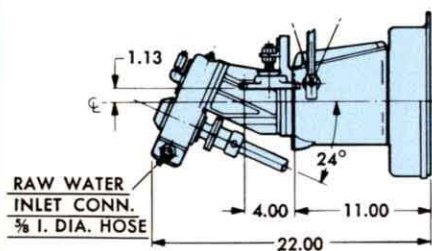
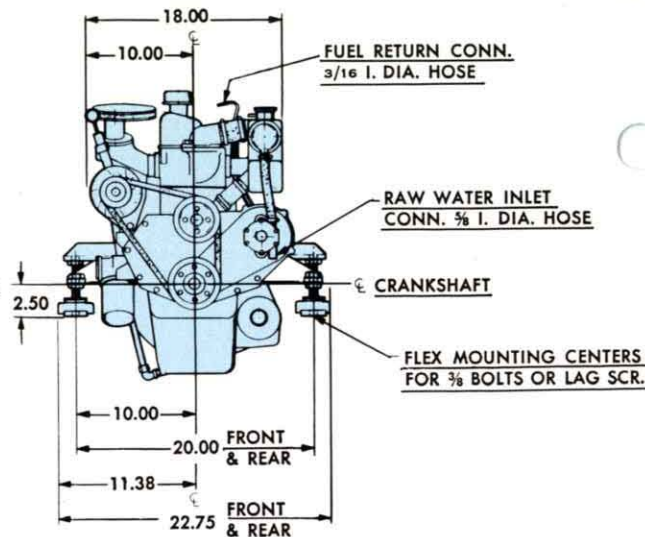

J type manual gear shown with vee drive, 1:1, 1.67:1 or 2:1 reduction. Weight 66 pounds, turns left hand propeller. J type gear also available in standard configuration, 1:1 or 2:1 reduction. Reduction is offset 3.88" down from crankshaft centerline.

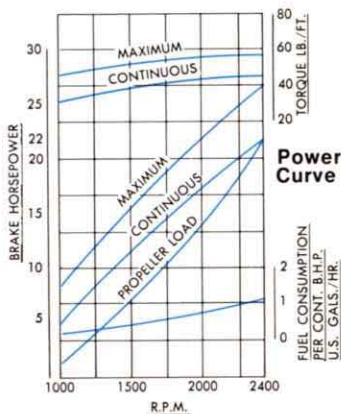

SPECIFICATIONS

Type: Four cylinders in line, four cycle fresh water cooled diesel.

Displacement: 97.6 cu. in. Bore 3.189" (81 mm), stroke 3.055" (77.6 mm).

Power: 22 hp at 2400 rpm (see power curve).

Compression Ratio: 18:1.

Weight: 334 lbs. basic engine. Add gear weights above for IOR weight.

Fuel Injection Equipment: CAV distributor type injection pump and nozzles. Direct injection combustion chambers.

Cylinder Block: Strongly ribbed cast iron.

Cylinder Head: Cast iron with large cooling water passages.

Crankshaft: Forged steel, counter balanced. Drilled holes conduct oil to all bearing journals.

Main Bearings: Five, 2 1/8" diameter, for maximum crankshaft support.

Camshaft: Heat treated forged steel. Three supporting bearings.

Pistons: Forged aluminum. Two compression rings, one oil control ring.

Connecting Rods: Heavy duty forged steel.

Lubrication: Externally mounted camshaft-driven pump.

Mounting: Adjustable flexible mounts on 20" centers.

Exhaust Manifold: Fresh water cooled.

Cooling System: Closed circuit fresh water system. Heat exchanger, fresh and raw water pumps mounted on engine.

Angle of Installation: 12° maximum.

Electrical System: 12-volt negative ground system with 45-ampere alternator standard.

Transmission: See above for specifications and propeller rotation.

STANDARD EQUIPMENT

Fresh water cooling system with heat exchanger, surge tank and pumps mounted on engine, adjustable flexible mounts; propeller shaft coupling; clutch lever with lower extension for remote control where applicable; spin-on full flow lube oil filter, sump pump and hose; flexible fuel hoses for supply and return, engine-mounted secondary fuel oil filter, fuel lift pump with hand primer, hydraulically governed fuel injection system; 12-volt 45-ampere alternator with transistor regulator; plug-in engine pre-wiring including pre-wired start panel with 10-foot cable; threaded 1/4" IPS exhaust flange; fully illustrated Instruction Manual and Parts List.

OPTIONAL EQUIPMENT

High efficiency primary fuel filter with water alarm; water-injected exhaust elbow; Hydro-Hush stainless steel water lift muffler; pre-wired all-electric instrument panel with 10-foot cable; extra 10-foot cable for instrument panels or starting panel; high water temperature, low oil pressure alarm system; flexible shaft coupling; special engine mounts, spare parts kits.

WESTERBEKE L-25

The WESTERBEKE L-25 is the lightest diesel for its power you can buy. It is the first diesel able to compete with gasoline engines on a performance per pound basis. Even with fresh water cooling, 2:1 reduction gear, adjustable, flexible mounts and plug-in engine pre-wiring, the L-25 weighs about the same as gasoline engines of similar performance.

The WESTERBEKE L-25 is one of the smoothest and quietest diesel engines we have ever seen. Although light, it is strong where it counts, dependable and durable.

The WESTERBEKE L-25 is available with direct drive, built-in lightweight 2:1, or a vee drive, making it sufficiently versatile for most boats in the 30-38 foot range. If you want a lightweight, durable, and quiet diesel with Westerbeke reliability, try the WESTERBEKE L-25.

Westerbeke marine engines and related products are sold and serviced by Westerbeke distributors in major port cities in North America.



THE WESTERBEKE CORP.

AVON INDUSTRIAL PARK, AVON, MASS. 02322 • (617) 588-7700
CABLE: WESTCORP, AVON • TELEX: 92-4444

WESTERBEKE L-25 lightweight marine diesel engine

Features:

- **Lightweight**, about the same as a gasoline engine of similar performance.
- **Rugged and Dependable**, strong where strength is needed.
- **Ideal for Ocean Racers**, where weight is important.
- **Smooth and Quiet** for cruising.

C & C 38

WESTERBEKE L-25
with standard
direct drive.

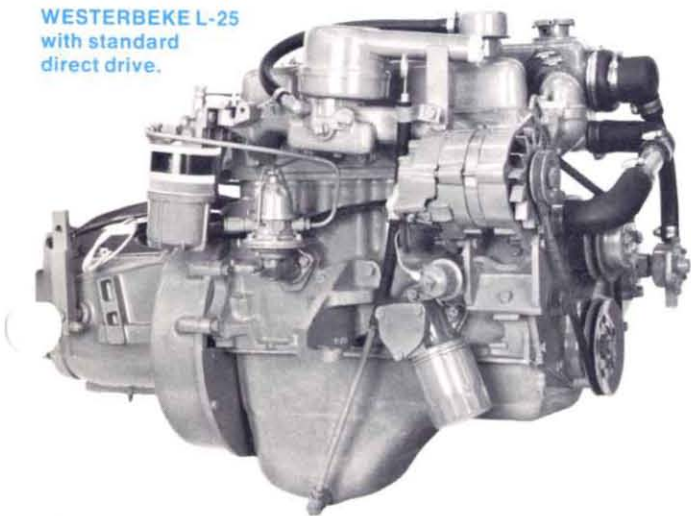

WESTERBEKE L-25
Short Profile
with 2:1
Sailing Gear.

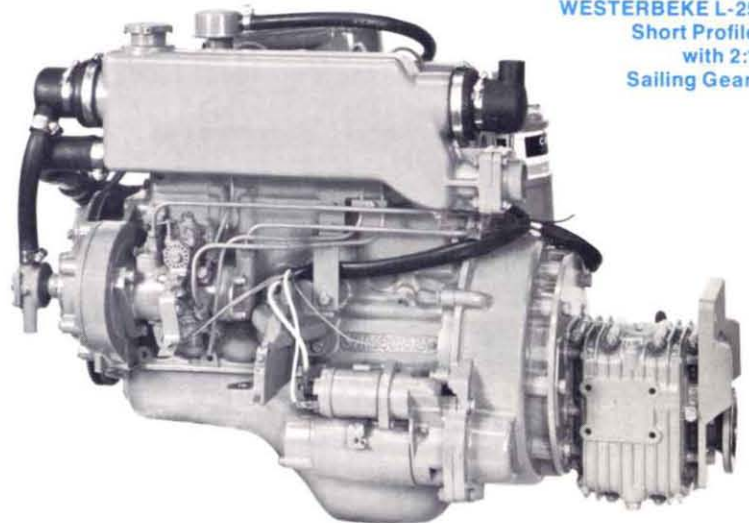

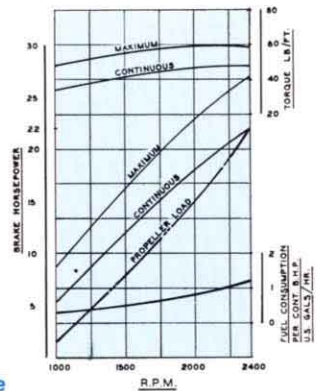
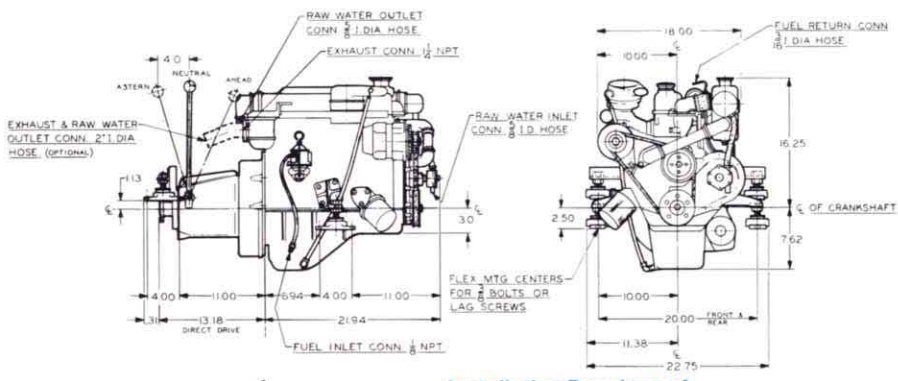

Installation Drawings of WESTERBEKE L-25 with standard direct drive. Gear weighs 26 pounds, turns left hand propeller.

Westerbeke Short Profile Sailing Gear with built-in 2:1 reduction. Weighs 25 pounds, turns right hand propeller.

Vee Drive, 2:1 or 2.6:1 reduction. Weighs 66 pounds, turns left hand propeller.

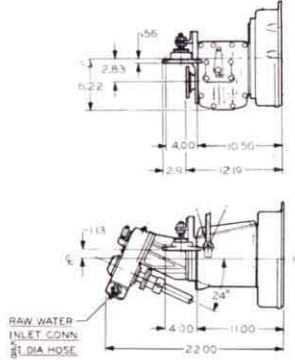

SPECIFICATIONS

- Type:** Four cylinders in line, four cycle fresh water cooled diesel.
- Displacement:** 97.6 cu. in. Bore 3.189" (81 mm), stroke 3.055" (77.6 mm).
- Power:** 22 hp at 2400 rpm (see power curve).
- Compression Ratio:** 18:1.
- Weight:** 334 lbs. basic engine. Add gear weights above for IOR weight.
- Fuel Injection Equipment:** CAV distributor type injection pump and nozzles. Direct injection combustion chambers.
- Cylinder Block:** Strongly ribbed cast iron.
- Cylinder Head:** Cast iron with large cooling water passages.
- Crankshaft:** Forged steel, counter balanced. Drilled holes conduct oil to all bearing journals.
- Main Bearings:** Five, 2 1/8" diameter, for maximum crankshaft support.
- Camshaft:** Heat treated forged steel. Three supporting bearings.
- Pistons:** Forged aluminum. Two compression rings, one oil control ring.
- Connecting Rods:** Heavy duty forged steel.
- Lubrication:** Externally mounted camshaft-driven pressure pump. Full flow spin-on lube oil filter.
- Mounting:** Adjustable flexible mounts on 20" centers. Special mounts available on request.
- Exhaust Manifold:** Fresh water cooled.
- Cooling System:** Closed circuit fresh water system. Heat exchanger, fresh and raw water pumps mounted on engine.
- Angle of Installation:** 12° maximum.
- Electrical System:** 12-volt negative ground system with 45-ampere alternator standard.
- Transmission:** See above for specifications and propeller rotation.

STANDARD EQUIPMENT

Fresh water cooling system with heat exchanger, surge tank and pumps mounted on engine, adjustable flexible mounts; propeller shaft coupling; clutch lever with lower extension for remote control where applicable; spin-on full flow lube oil filter, sump pump and hose; flexible fuel hoses for supply and return, engine-mounted secondary fuel oil filter, fuel lift pump with hand primer, hydraulically governed fuel injection system; 12-volt 45-ampere alternator with transistor regulator; plug-in engine pre-wiring including pre-wired start panel with 10-foot cable; threaded 1 1/4" IPS exhaust flange; fully illustrated Instruction Manual and Parts List.

OPTIONAL EQUIPMENT

High efficiency primary fuel filter; water-injected exhaust elbow; Hydro-Hush stainless steel water lift muffler; pre-wired all-electric instrument panel with 10-foot cable; extra 10-foot cable for instrument panels or starting panel; high water temperature, low oil pressure alarm system; flexible shaft coupling; special engine mounts, spare parts kits.

WESTERBEKE L-25

The WESTERBEKE L-25 is the lightest diesel for its power you can buy. It is the first diesel able to compete with gasoline engines on a performance per pound basis. Even with fresh water cooling, 2:1 reduction gear, adjustable, flexible mounts and plug-in engine pre-wiring, the L-25 weighs about the same as gasoline engines of similar performance.

The WESTERBEKE L-25 is one of the smoothest and quietest diesel engines we have ever seen. Although light, it is strong where it counts, dependable and durable.

The WESTERBEKE L-25 is available with direct drive, built-in lightweight 2:1, or a vee drive, making it sufficiently versatile for most boats in the 30-38 foot range. If you want a lightweight, durable, and quiet diesel with Westerbeke reliability, try the WESTERBEKE L-25.

Westerbeke marine engines and related products are sold and serviced by Westerbeke distributors in major port cities in North America.



J. H. WESTERBEKE CORP.

AVON INDUSTRIAL PARK, AVON, MASS. 02322 • (617) 588-7700
 CABLE: WESTCORP, AVON • TELEX: 92-4444